



Glavno

Range of product	Harmony XAC
Product or component type	Pendant control station
Device short name	XACD

Komplementarno

Control station type	Double insulated
Enclosure material	Polypropylene
Control type	Intuitive
Electrical circuit type	Power circuit
Enclosure type	Complete ready for use
Control station application	Control of single speed hoist motor
Motor starter type	Reversing
Control station composition	1 2-directional button
Control button type	First direction button 2-pole raise, slow Second direction button 2-pole lower, slow
Product compatibility	XEDS2111 for reversing operation
Mechanical interlocking	With mechanical interlocking
Control station colour	Yellow
Connections - terminals	Screw clamp terminals 1 x 2.5 mm ² with or without cable end Screw clamp terminals 2 x 1.5 mm ² with or without cable end
Standards	EN/IEC 60204-32 EN/IEC 60947-5-1 UL 508 CSA C22.2 No 14
Protective treatment	TH
Ambient air temperature for operation	-25...70 °C
Ambient air temperature for storage	-40...70 °C
Vibration resistance	15 gn 10...500 Hz IEC 60068-2-6
Shock resistance	100 gn IEC 60068-2-27
Overvoltage category	Class II IEC 61140
IP degree of protection	IP65 IEC 60529
IK degree of protection	IK08 EN 50102
Mechanical durability	3000000 cycles
Cable entry	Rubber sleeve with stepped entry 7...18 mm
[I _{th}] conventional enclosed thermal current	16 A
[U _i] rated insulation voltage	500 V 3 IEC 60947-1
[U _{imp}] rated impulse withstand voltage	6 kV IEC 60947-1
Contact operation	Snap action
Operating force	28 N
Short-circuit protection	<= 6 A fuse protection cartridge aM
Rated operational power in W	1100 W AC-3 400 V IEC 60947-3 appendix A 1100 W AC-4 400 V IEC 60947-3 appendix A
Electrical durability	1000000 cycles AC-3 1100 W 400 V 10 cyc/mn 0.4 IEC 60947-3 appendix A 1000000 cycles AC-4 1100 W 400 V 10 cyc/mn 0.4 IEC 60947-3 appendix A

Informacije dane u ovoj dokumentaciji sadrže opće opise i/ili tehničke karakteristike o performansama ovdje sadržanih proizvoda. Ova dokumentacija nije namijenjena kao zamjena za niti bi se trebala koristiti za određivanje prikladnosti ili pouzdanosti predmetnih proizvoda za konkretne korisničke primjene. Svaki takav korisnik ili integrator dužan je provesti odgovarajuću i potpunu analizu rizika, procjenu i ispitivanje proizvoda u odnosu na odgovarajuću specifičnu primjenu ili uporabu istog. Niti društvo Schneider Electric Industries SAS niti bilo koje od njegovih povezanih poduzeća ili podružnica neće preuzeti obvezu ili snositi odgovornost za pogrešnu upotrebu ovdje sadržanih informacija.

Terminals description ISO n°1	(1-2)P (3-4)P (5-6)P (7-8)P
Terminal identifier	(11-12)NC (13-14)NO
Product weight	0.355 kg

Okolina

Contractual warranty

Warranty period	18 months
-----------------	-----------

Dimensions

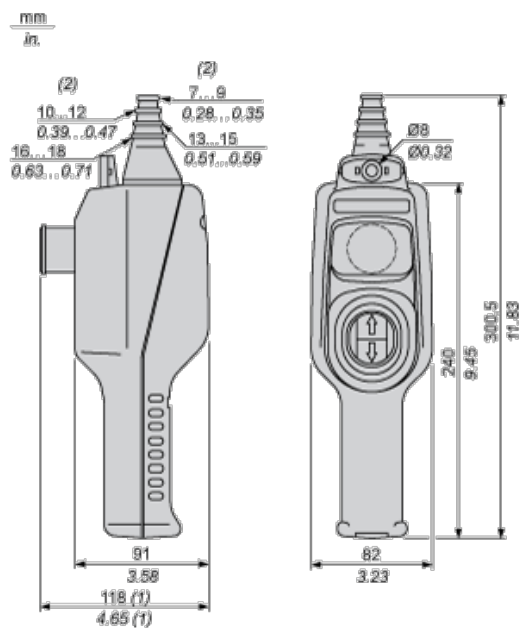

- (1) With trigger action latching \varnothing 30 mm / 1.18 in. Emergency stop.
- (2) Internal \varnothing

Control of Single-Speed Reversing Motor 2-Phase Switching

