

XPEG211

jednostruka nožna sklopka – IP66 – bez poklopca –
plastična – siva – 2 NC + 2 NO



Glavno

Range of product	Harmony XPE
Product or component type	Foot switch
Material	Plastic
Foot switch type	Single foot switch
Device short name	XPEG
Trigger mechanism	Without trigger mechanism
Contact operation	2 steps
Contacts type and composition	2 NC + NO
Colour	Grey

Komplementarno

Positive opening	With conforming to EN/IEC 60947-5-1 appendix K
Connections - terminals	Screw clamp terminal: $\leq 1 \times 2.5 \text{ mm}^2$ with or without cable end Screw clamp terminal: $\leq 2 \times 1.5 \text{ mm}^2$ with or without cable end
Cable entry	2 plain holes for M20 cable gland
Mechanical durability	10000000 cycles
[Ie] rated operational current	3 A, 240 V, AC-15, A300 0.27 A, 250 V, DC-13, Q300 conforming to EN/IEC 60947-5-1 appendix A
[Ui] rated insulation voltage	500 V, degree of pollution: 3 conforming to EN/IEC 60947-1 500 V, degree of pollution: 3 conforming to NF C 20-040 group C 500 V, degree of pollution: 3 conforming to VDE 0110 group C 300 V conforming to UL 508 300 V conforming to CSA C22.2 No 14
[Uimp] rated impulse withstand voltage	6 kV conforming to EN/IEC 60947-1
Resistance across terminals	$\leq 25 \text{ MOhm}$ conforming to IEC 60255-7 category 3 $\leq 25 \text{ MOhm}$ conforming to NF C 93-050 method A
Short-circuit protection	10 A by cartridge fuse type gG conforming to EN/IEC 60947-5-1 10 A by cartridge fuse type gG conforming to VDE 0660-200
Rated operational power in W	10 W DC-13, operating rate: 60 cyc/mn, 5000000 cycles, 24 V, load factor: 0.5 conforming to EN/IEC 60947-5-1 appendix C 4 W DC-13, operating rate: 60 cyc/mn, 5000000 cycles, 120 V, load factor: 0.5 conforming to EN/IEC 60947-5-1 appendix C 7 W DC-13, operating rate: 60 cyc/mn, 5000000 cycles, 48 V, load factor: 0.5 conforming to EN/IEC 60947-5-1 appendix C
Product weight	0.57 kg

Okolina

standards	EN/IEC 60947-5-1 UL 508 CSA C22.2 No 14
product certifications	CSA UL
protective treatment	TH
ambient air temperature for operation	-25...70 °C
ambient air temperature for storage	-40...70 °C
vibration resistance	5 gn ($f = 10 \dots 500 \text{ Hz}$) conforming to IEC 60068-2-6
shock resistance	30 gn conforming to IEC 60068-2-27
overvoltage category	Class II conforming to EN/IEC 61140 Class II conforming to NF C 20-030
IP degree of protection	IP66 conforming to IEC 60529

Informacije dane u ovoj dokumentaciji sadrže opće opise i/ili tehničke karakteristike o performansama ovdje sadržanih proizvoda. Ova dokumentacija nije namijenjena kao zamjena za niti bi se trebala koristiti za određivanje prikladnosti ili pouzdanosti predmetnih proizvoda za konkretne korisničke primjene. Svaki takav korisnik ili integrator dužan je provesti odgovarajuću i potpunu analizu rizika, procjenu i ispitivanje proizvoda u odnosu na odgovarajuću specifičnu primjenu ili uporabu istog. Niti društvo Schneider Electric Industries SAS niti bilo koje od njegovih povezanosti poduzeća ili podružnica neće preuzeti obvezu ili snositi odgovornost za pogrešnu upotrebu ovdje sadržanih informacija.

Contractual warranty

Warranty period

18 months

Plastic Foot Switch without Protective Cover

Dimensions

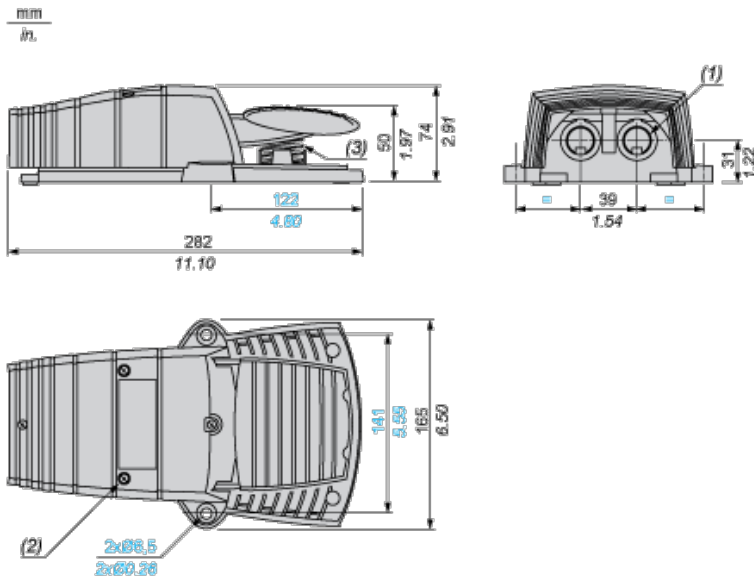

- (1) 2 plain holes for ISO M20 or n° 13 (Pg 13.5) cable gland.
- (2) 4 cover fixing screws: stainless steel. Tightening torque: 1 N.m.
- (3) Return spring: stainless steel.

Electrical Durability of Contacts

AC-15 Utilization Category

Operating rate: 3600 operating cycles/hour. Load factor: 0.5.

Inductive circuit:

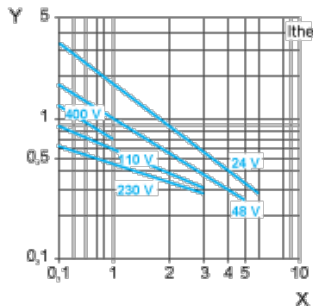

X Current in A

Y Millions of operating cycles

DC-13 Utilization Category

Refer to the product characteristic "Operational power in W".